

TYPICAL DOUBLE TEE CONNECTION

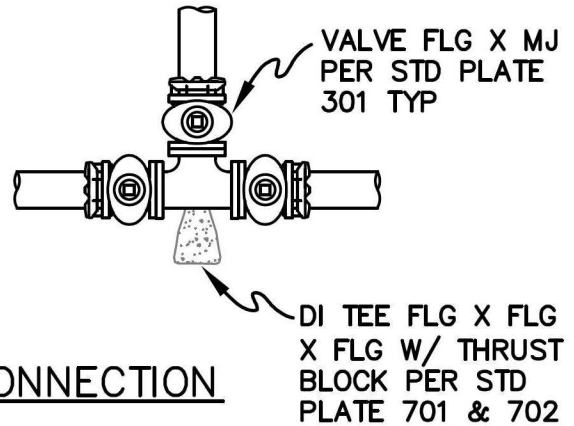
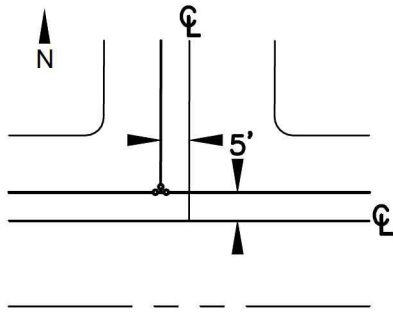

TYPICAL TEE CONNECTION

NOTES:

1. VALVES SHALL BE LOCATED ON EACH BRANCH OF WATER MAIN INTERSECTIONS. WHERE RELATIVELY SHORT LINES LESS THAN 500 FEET IN LENGTH ARE INVOLVED, ONE OF THE TWO VALVES BETWEEN INTERSECTIONS MAY BE OMITTED.
2. WATER MAINS IN PUBLIC STREETS SHALL BE LOCATED PARALLEL TO AND 5-FEET NORTH OR WEST OF STREET CENTERLINES WHENEVER POSSIBLE.
3. SEE PLATE NO. 701, 702, & 703 FOR THRUST & ANCHOR BLOCK DETAILS.
4. SEE PLATE NO. 301 FOR VALVE BOX DETAILS.
5. REFER TO SECTIONS 4.4 "MAIN LINE FITTINGS" AND SECTION 6.12 "INSTALLATION OF VALVES AND FITTINGS" FOR INFORMATION CONCERNING THE INSTALLATION AND WRAPPING OF BOLTED CONNECTIONS.
6. ALL MATERIALS AND CONSTRUCTION SHALL MEET THE REQUIREMENTS AS SPECIFIED IN THE DISTRICT'S "WATER DESIGN AND CONSTRUCTION STANDARDS" MANUAL.
7. PRE-APPROVED MANUFACTURES AND MODEL NUMBERS ARE LISTED IN THE DISTRICT'S "APPROVED MATERIALS LIST FOR WATER IMPROVEMENT PROJECTS."



**Ventura County
Waterworks
District No. 8**

**WATERMAIN CONNECTIONS
AT INTERSECTIONS**

RECOMMENDED: */s/*
DEPUTY DIRECTOR / DISTRICT ENGINEER

APPROVED: */s/*
DIRECTOR OF PUBLIC WORKS

JUL 2021

PLATE
207