

**END-OF-MAIN CONNECTION
(PLAN VIEW)**

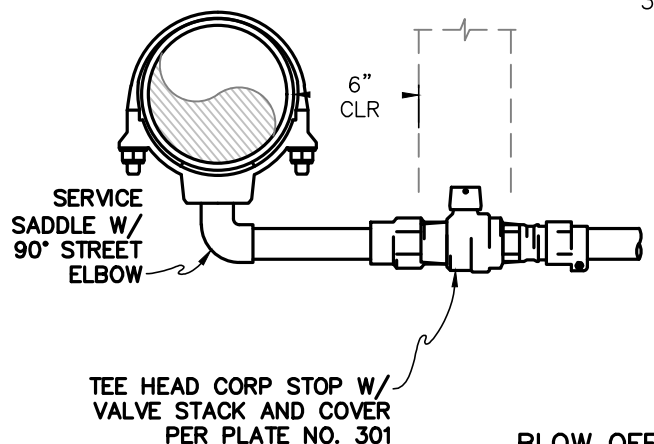

**BLOW OFF CONNECTION
AT LOW POINT ON MAIN**

- NOTES**
1. SERVICE LINE TO BE LAID UPHILL AT POSITIVE SLOPE, 2% MIN.
 2. ALL PIPING SHALL BE EXTRA STRONG BRASS, UNLESS OTHERWISE NOTED.
 3. ALL MATERIALS AND CONSTRUCTION SHALL MEET THE REQUIREMENTS AS SPECIFIED IN THE DISTRICT'S "WATER DESIGN AND CONSTRUCTION STANDARDS" MANUAL.
 4. PRE-APPROVED MANUFACTURES AND MODEL NUMBERS ARE LISTED IN THE DISTRICT'S APPROVED MATERIALS LIST.

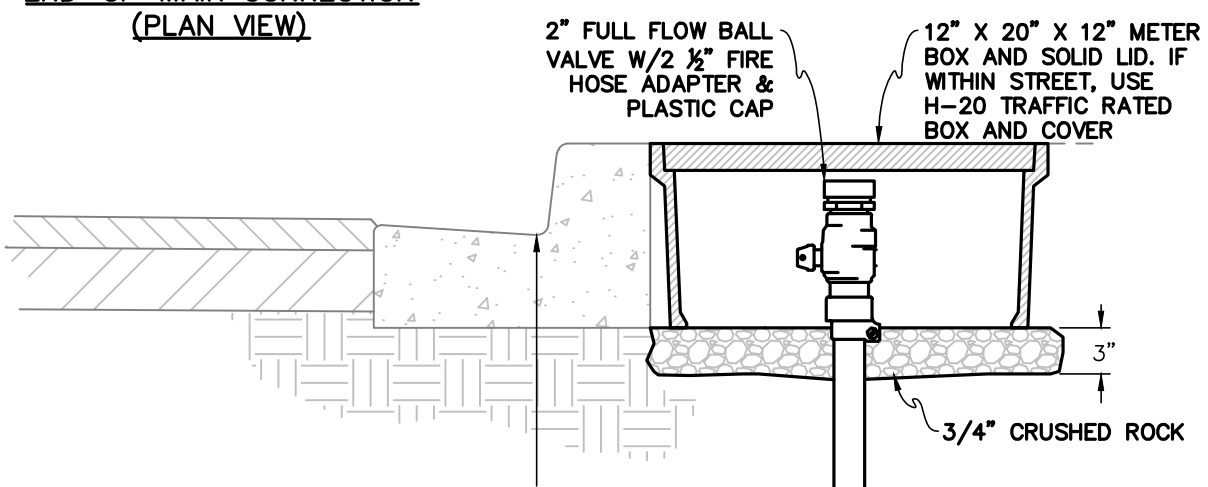

**Ventura County
Waterworks
District No. 8**

2" BLOW OFF INSTALLATION

JUN 2023

RECOMMENDED: /s/
DEPUTY DIRECTOR / DISTRICT ENGINEER

APPROVED: /s/
DIRECTOR OF PUBLIC WORKS

PLATE
502